

403D-07

6.0 kW @ 1500 rpm

400

Series

Electropak

Basic technical data

Number of cylinders	3
Cylinder arrangement	Vertical inline
Cycle	4 strokes
Induction system	Naturally aspirated
Combustion system	Indirect injection
Compression ratio	23.5:1
Bore	67.0 mm
Stroke	72.0 mm
Cubic capacity	0.761 litres
Direction of rotation when viewed from flywheel	Anticlockwise
Firing order	1, 2, 3

Dry weight

Engine with options 87 kg

Overall dimensions

(with radiator and air filter fitted)

Height	630 mm
Length	645 mm
Width	442 mm

Moment of inertia - engine - (mk²)

Engine rotational components	0.009 kgm ²
Flywheel (option number) DD003	0.534 kgm ²

Centre of gravity (engine)

From rear face of cylinder block	85 mm
Height above crankshaft centreline	63 mm
Offset to RHS from centreline	-3 mm

Performance

Note: All performance data based on operation to ISO Standard reference: ISO 3046-1 :2002

All ratings certified to within $\pm 5\%$

Test conditions

Air temperature	25°C
Barometric pressure	100 kPa
Relative humidity	30%
Air inlet restriction at maximum power (nominal)	3.0 kPa
Exhaust back pressure at maximum power (nominal)	9.0 kPa
Fuel temperature (inlet pump)	40.0°C

Noise data

Average sound pressure level for bare engine (without inlet and exhaust) at 1 metre

1500 rpm	72.6 dB
----------	---------

General installation

Designation	Units	403D-07 6.0 kW @ 1500 rpm	
		Prime	Standby
Gross engine power	kWb	5.5	6.0
Brake mean effective pressure	kPa	572.6	630.9
Mean piston speed	m/s	3.6	
Combustion air flow	m ³ /min	0.63	
Exhaust gas flow (maximum)	m ³ /min	0.8	1.02
Exhaust gas temperature (maximum)	°C	400	450
Overall thermal efficiency (nett)	%	32.8	32.6
Assumed alternator efficiency	%	83.2	
Typical generating set output (0.8 pf 25°C)	kWe	4.5	4.9
	kVA	5.6	6.1

Energy balance

Designation	Units	403D-07 6.0 kW @ 1500 rpm	
		Prime	Standby
Energy in fuel (fuel heat of combustion)	kWt	16.6	18.4
Energy to power (gross)	kWt	5.5	6.0
Energy to cooling fan	kWt	0.1	
Energy to power (nett)	kWm	5.4	5.9
Energy to coolant and lubricating oil	kWt	5.3	5.9
Energy to exhaust	kWt	4.4	4.9
Heat to radiation	kWt	1.5	1.6

Cooling system

Radiator

Face area	0.084 m ²
Matrix density and material	11.3 fins/inch aluminium
Width of matrix	324.6 mm
Height of matrix	259.2 mm
Pressure cap setting	90 kPa

Fan

Type	Pusher
Diameter	280 mm
Drive ratio	1.23:1
Number of blades	5
Material	Plastic
Power absorbed @ maximum rated speed	0.10 kW

Coolant

Total system capacity (1.4 radiator + 1.2 engine)	2.6 litres
Bare engine capacity	1.2 litres
Maximum top tank temperature (sea level)	112°C
Thermostat operation range	82-95°C

Note: Recommended coolant: 50% anti-freeze/50% soft water.
For details of recommended coolant specifications, please refer to the Operation and Maintenance Manual (OMM) for this engine model.

Maximum additional restriction (duct allowance) to cooling airflow and resultant minimum airflow		
Pusher fan	Unit	Engine speed 1500 rpm
Ambient clearance 50% glycol	°C	46
Duct allowance	Pa	60
Cooling fan airflow	m ³ /sec	0.17

Note: Radiator is currently supplied loose.

Electrical system

Alternator voltage	12 volts
Alternator output	14 amps
Starter motor voltage	12 volts
Number of teeth on flywheel	88
Number of teeth on starter pinion	8
Engine stop method	Electric shut off solenoid

Cold start system

Air temperature	0°C/32°F	-15°C/5°F	-20°C/-4°F
Lubricating oil viscosity	20W	10W	5W
Battery (commercial ref. no)	49	49	69
Starter motor (kW)	0.8	0.8	1.2

Exhaust system

Maximum back pressure	10.2 kPa
Exhaust outlet diameter (internal)	34.0 mm

Load acceptance

The below complies with the requirements of classification 3 and 4 of ISO 8528-12 and G2 operating limits stated in ISO 8528-5.

Initial load application: when engine reaches rated speed (15 seconds maximum after engine starts to crank)		
Pusher fan	Unit	Engine speed 1500 rpm
Description	Units	50 Hz
% of prime power	%	100
Load	kWm (kWe)	5.4 (4.5)
Transient frequency deviation	%	10 / -12
Frequency recovery	Seconds	5

The above figures were obtained under the following test conditions:
Ambient temperature

Ambient temperature	20°C
Governing mode	Mechanical
Alternator inertia	0.0573 kgm ²

Fuel system

Fuel injection system

Fuel pump type/model Cassette type
 Injection system Indirect fuel injection
 Injector type Throttle type
 Injection pressure 11760 kPa (nominal)

Fuel feed

Fuel lift pump type Mechanical driven by camshaft
 Maximum fuel supply depression at lift pump inlet 16.9 kPa
 Maximum suction head at lift pump inlet 0.8 m
 Maximum fuel temperature at lift pump inlet 45°C
 Maximum fuel filter service interval 500 hours

Governor

Type Mechanical

Fuel specification

EPA Part 1065.703 ULSD, EU 2004/26/EC Stage 3B/4

Fuel consumption

Power rating fuel consumption g/kWh	Unit	1500 rpm
110%	litres/hour	1.84
100%	litres/hour	1.66
75%	litres/hour	1.28
50%	litres/hour	0.93

Induction system

Maximum air intake restriction

Clean filter 3.0 kPa
 Dirty filter 6.4 kPa
 Air filter type Dry element type

Lubrication system

Maximum sump capacity 3.05 litres
 Minimum sump capacity 2.35 litres
 Maximum oil temperature - continuous operation 125°C
 Maximum oil temperature - intermittent operation 135°C
 Oil consumption at full load rated speed (% of fuel) 0.1%

Lubricating oil pressure

	Unit	1500 rpm
Minimum	kPa	150.0
Oil relief valves opens at	kPa	225.6 - 343.2
Lubricating oil flow at rated speed	litres/min	6.8

Normal operating angles

Front and rear 35°

Recommended SAE viscosity

A multigrade oil conforming to API-CJ4 / CK4 to be used.

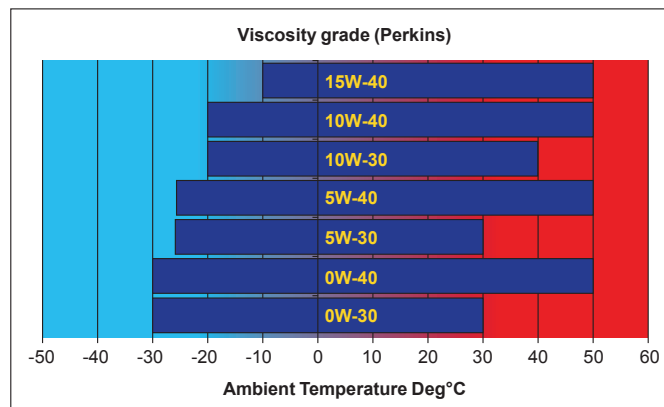

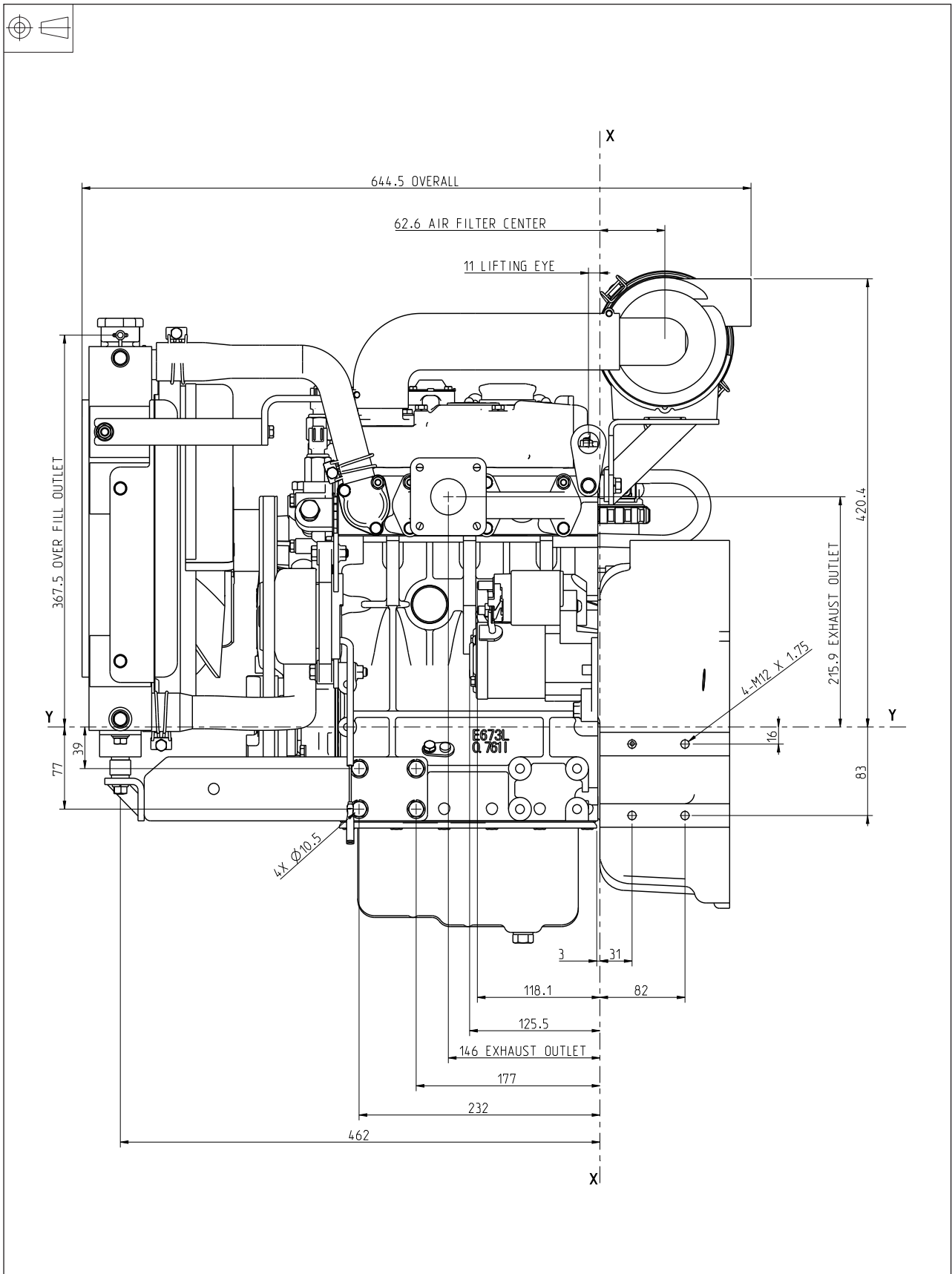

403D-07 - Front view

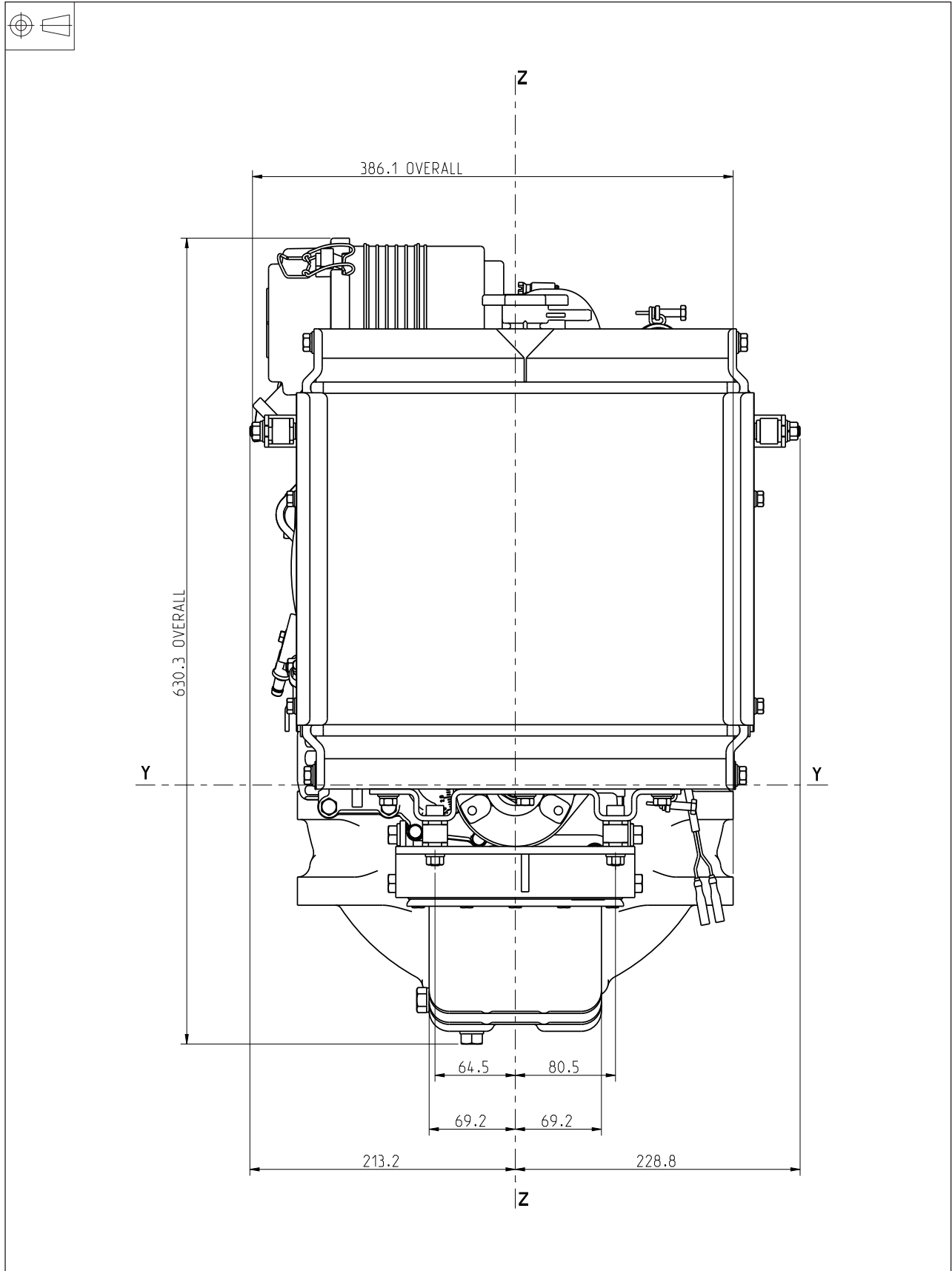

403D-07 - Right side view

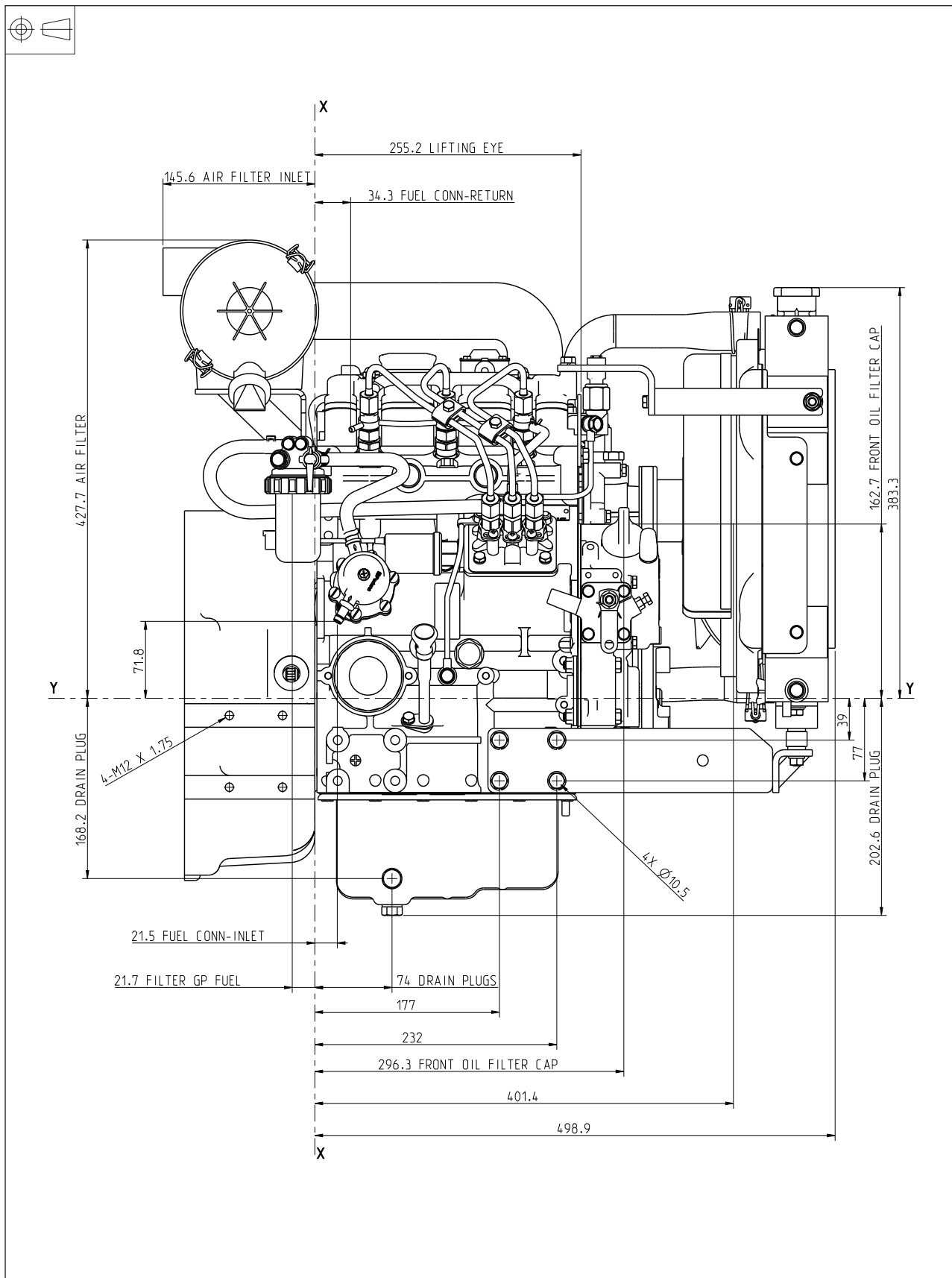

403D-07 - Rear view

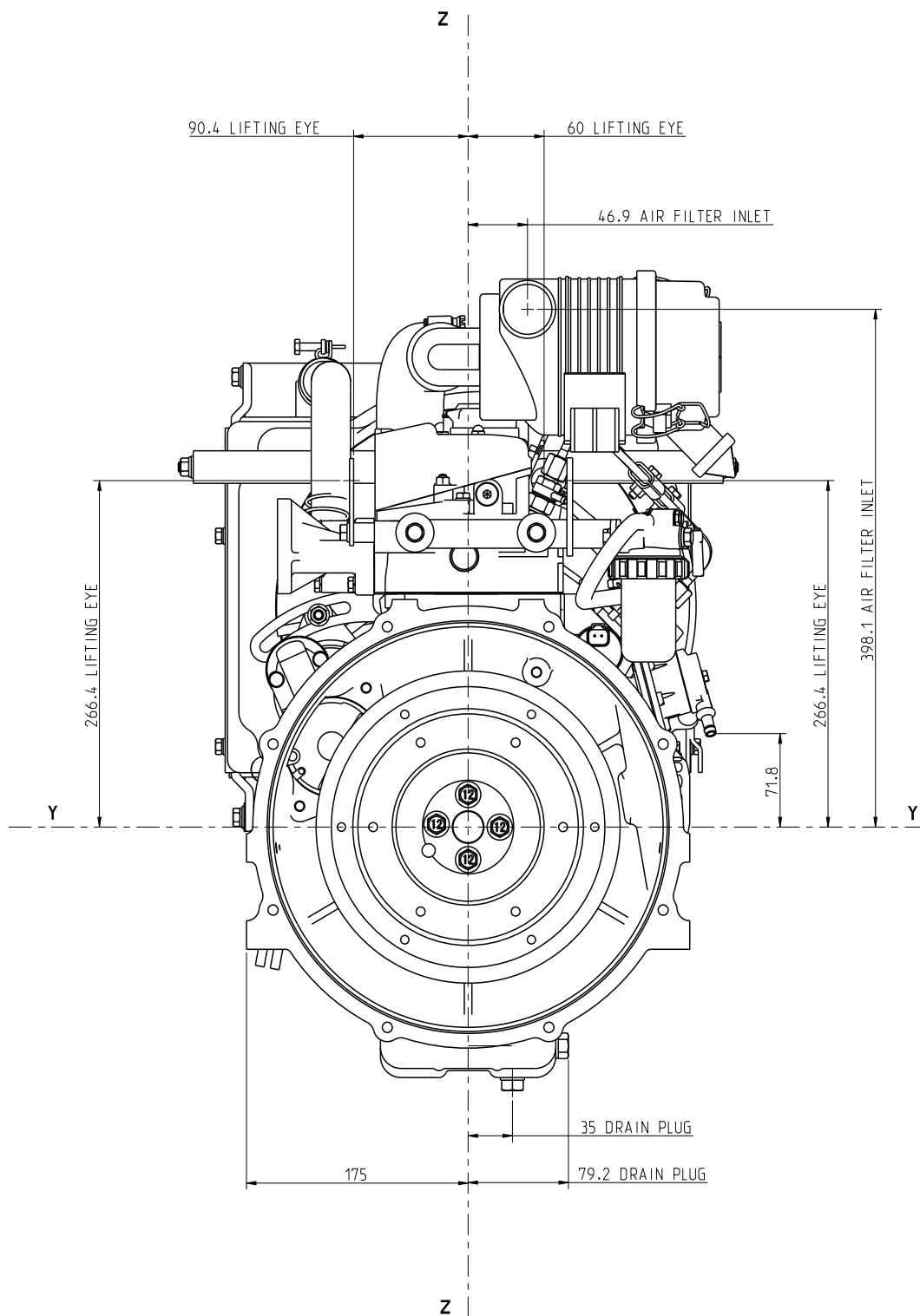

403D-07 - Plan view

