

Technical Data

4000 Series

4008-30TRS1

4008-30TRS2

Gas Engine

Basic technical data

Number of cylinders .. 8
 Cylinder arrangement .. vertical, In line
 Cycle .. 4 stroke, spark ignition
 Induction system .. turbo charged
 Compression ratio .. 12:1 nominal
 Bore .. 160 mm
 Stroke .. 190 mm
 Cubic capacity .. 30,561 litres
 Direction of rotation .. anti-clockwise viewed on flywheel
 Firing order .. 1, 4, 7, 6, 8, 5, 2, 3
 Cylinder 1 .. furthest from flywheel
 Total weight of cogeneration unit (engine only)
 Estimated total weight (dry) .. 3350 kg
 Estimated total weight (wet) .. 3528 kg

Overall dimensions

	Height mm	Length mm	Width mm
Cogeneration unit			
Natural gas	1671	2559	1400
Bio gas	1782	2559	1418
Electro unit			
Natural gas	1671	2658	1633
Bio gas	1782	2658	1633

Moment of inertia (GD²)

-engine .. 4,12 kgm²
 -flywheel .. 5,92 kgm²
 Cyclic irregularity for engine/flywheel:
 4008-30TRS1 - 447 kW .. 1:215
 4008-30TRS2 - 526 kW .. 1:194

General installation

Designation	Units	Continuous baseload rating			
		Cogeneration unit		Electro unit	
		TRS1	TRS2	TRS1	TRS2
Gross engine power	kW	447	526	447	526
Brake mean effective pressure	kPa	1170	1370	1170	1370
Combustion air flow	m ³ /min	34	40	34	40
Exhaust gas temperature (max) after turbo	°C	490	485	490	485
Exhaust gas flow (max)	m ³ /min	90	105	90	105
Boost pressure ratio	-	2,53	2,90	2,53	2,90
Overall electrical efficiency	%	37,9	38,5	37,4	38,0
Mean piston speed	m/s	9,5		9,5	
Charge coolant flow	l/sec	8,3		8,3	
Nominal excess air factor (Lambda)	λ	1,71	1,70	1,71	1,70
Typical gross Genset 25 °C (100 kPa) Electrical output (unity 1.0pf)	kWe	425	500	425	500
Assumed alternator efficiency	%	95,0		95,0	

Continuous baseload rating: Power available for continuous full load operation. No overload available.

Ratings

This is defined in ISO3046 / 1 (BS5514 / 1 - 1982)
 Electrical ratings are based on stated alternator efficiency and are for guidance only. For Load Acceptance figures, please refer to Stafford Applications Engineering Department.

Operating point

Engine speed .. 1500 rev/min.
 Ignition timing .. 24° BTDC
 Inlet manifold mixture temperature .. 50 °C
 Cooling water exit temperature .. < 96 °C
 Exhaust emission .. according to TA-Luft (NOx)

Fuel data

Lower calorific value .. 34,710 kJ/Sm³ (45.671 kJ/kg)
 Density .. 0,76 kg/Sm³
 Stoichiometric air requirement .. 16 kJ/kg
 Minimum methane number before derate .. 75

Performance

Steady state speed stability at constant load .. ± 0,25%
Note: All data based on operation to ISO 3046/1, BS 5514 and DIN 6271 standard reference conditions.

Test conditions

-air temperature .. 25 °C
 -barometric pressure .. 100 kPa
 -relative humidity .. 30%

Energy balance

4008-30TRS1 / 4008-30TRS2 - Cogeneration unit

Designation	TRS1		TRS2	
	Continuous baseload rating	%	Continuous baseload rating	%
Energy in fuel	1119	100	1298	100
Energy in power output (Net)	447	39,9	526	40,5
Energy in exhaust	350	31,3	398	30,6
Energy to coolant and oil	189	16,9	211	16,3
Energy to charge cooler	67	6,0	90	6,9
Sum of useable heat	539	48,1	602	46,4
Sum of useable energy	986	88,1	1135	87,4
Energy to radiation	66	5,9	73	5,7

4008-30TRS1 / 4008-30TRS2 - Electro unit

Designation	TRS1		TRS2	
	Continuous baseload rating kW	%	Continuous baseload rating kW	%
Energy in fuel	1134	100	1315	100
Energy in power output (Net)	447	39,4	526	40,0
Energy in exhaust	353	31,1	402	30,6
Energy to coolant and oil	193	17,0	216	16,4
Energy to charge cooler	69	6,1	92	7,0
Sum of useable heat	615	54,2	710	54,0
Sum of useable energy	1062	93,7	1236	94,0
Energy to radiation	72	6,3	79	6,0

Notes:

- Not to be used for CHP design purposes (indicative figures only). Consult Perkins Engines Company Limited.
- Assumes complete combustion.

Cooling system

Recommended coolant: 50% inhibited ethylene glycol or 50% inhibited propylene glycol and 50% clean fresh water. For combined heat and power systems and where there is no likelihood of ambient temperature below 10 °C, then clean 'soft' water may be used, treated with 1% by volume of Perkins inhibitor in the cooling system. The inhibitor is available in 1 litre bottles from Perkins.
 Total coolant capacity (engine only) 48 litres
 Maximum jacket water pressure in crankcase 1 bar (plus static pressure head)

Jacket cooling water data

Coolant flow 36 m³/h
 Coolant exit temperature (max) 96 °C
 Coolant entry temperature (max) 88 °C

Charge cooling water data

Coolant flow 30 m³/h
 Coolant entry temperature 45 °C
 Charge cooler fin and tube on engine
 Shutdown switch setting coolant 96 °C rising
 Coolant immersion heater capacity 4 kW 1 off

Lubrication system

Recommended lubricating oil: Lubricating oil requirements vary with fuel used. Full specifications including oil sampling and recommendations and condemnation limits appear on the Fuel, Coolant and Lubricating Oil Recommendation Sheet for the 4000 Series Gas Engines.

Lubricating oil capacity

Total system 165,6 litres
 Sump maximum 154,0 litres
 Sump minimum 127,0 litres

Lubricating oil temperature

Maximum to bearings 105 °C
 Lubricating oil pressure at 85 °C temperature to bearings 0,34 MPa
 Oil consumption (continuous rating)

Designation		TRS1	TRS2
After RUNNING-IN ††	g/kWhr	0,14	0,14
Oil flow rate from oil pump	l/s	3,7	3,7

†† Typical 250 hours

Sump drain plug tapping size GA1
 Oil pump gear driven
 Shutdown switch setting oil 1,93 bar falling

Normal operating angles:

-front and rear 5°
 -side tilt 22,5°

Fuel system

Recommended fuel: Natural Gas LHV at 34 MJ/m³ (930 Btu/cu.ft). Other fuels may be used, for example landfill or digester gas. Ratings will vary from those shown.

Where fuels other than Natural Gas are being considered it is imperative that a full gas analysis (including details of any solid or liquid components) be obtained. Reference should then be made to Perkins Engines Company Limited to determine suitability. Gas supplies must be filtered to the same standard as the engine intake air (i.e. Maximum particle size not to exceed 50 microns).
 Gas supply pressure 1,5 kPa to 5 kPa at full rated flow
 Carburettor type Deltec with zero pressure regulator
 Installation of gas supply and shut off valves to be in accordance with local regulations.

Designation	Cogeneration unit		Electro unit	
	TRS1	TRS2	TRS1	TRS2
Fuel consumption gross	kJ / kW	kJ / kW	kJ / kW	kJ / kW
At Continuous baseload rating	2,51	2,47	2,54	2,50
At 75% of Continuous base load rating	2,58	2,53	2,61	2,56
At 50% of Continuous baseload rating	2,81	2,70	2,84	2,73
At 25% of Continuous base rating	3,63	3,38	3,66	3,41

Fuel: Natural Gas - LHV = 34,71 MJ/m³

Tolerance on Fuel consumption

Designation		Cogeneration unit		Electro unit	
Mass flow data	Units	TRS1	TRS2	TRS1	TRS2
Fuel	Kg/h	88,2	102,3	89,3	103,6
Volume flow data (100 kPa)					
Fuel (15 °C)	Sm ³ /hr	116,1	134,6	117,6	136,3

4008-30TRS1 and 4008-30TRS2 Bio gas cogeneration unit - Left view

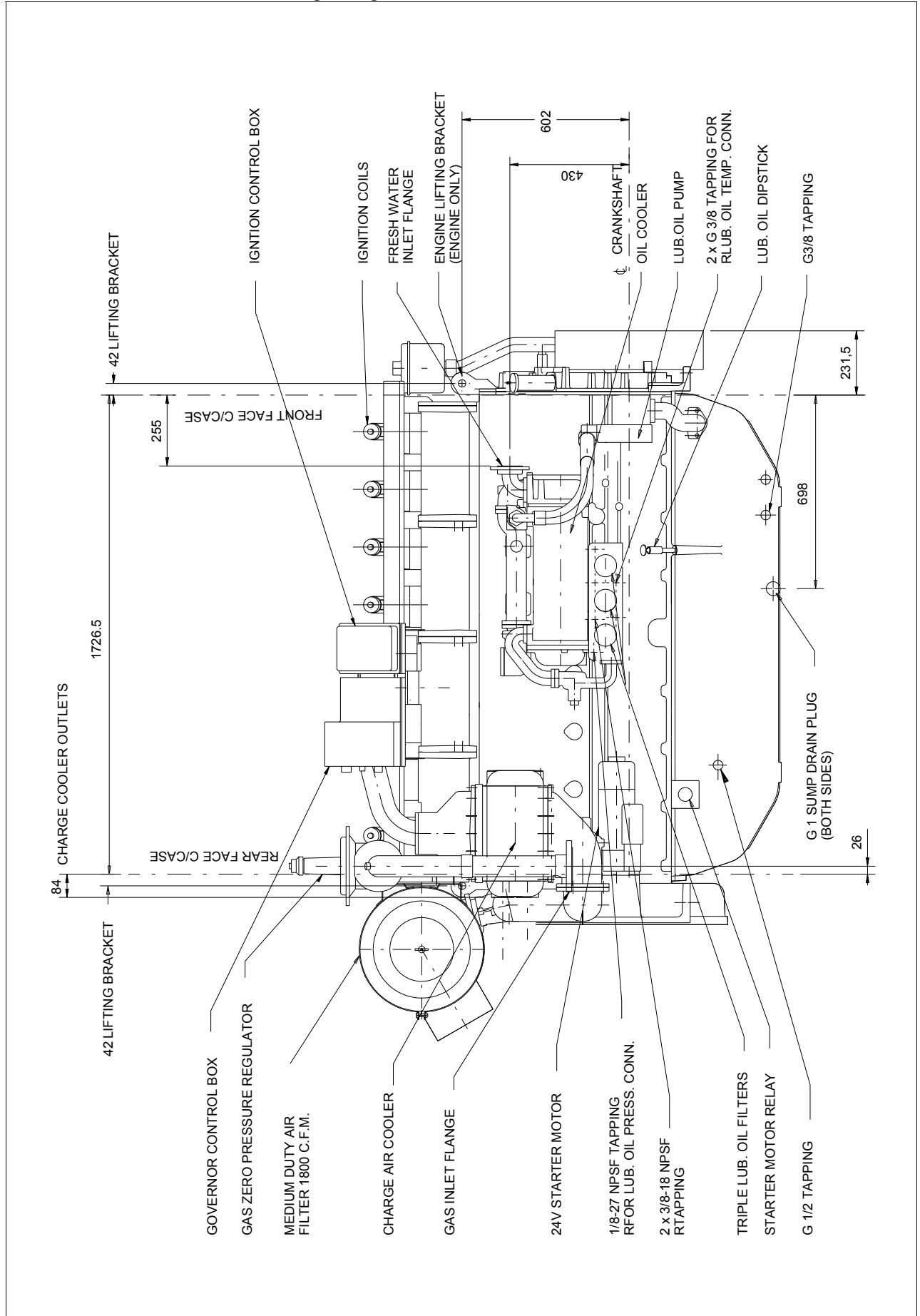

4008-30TRS1 and 4008-30TRS2 Bio gas cogeneration unit - Front view

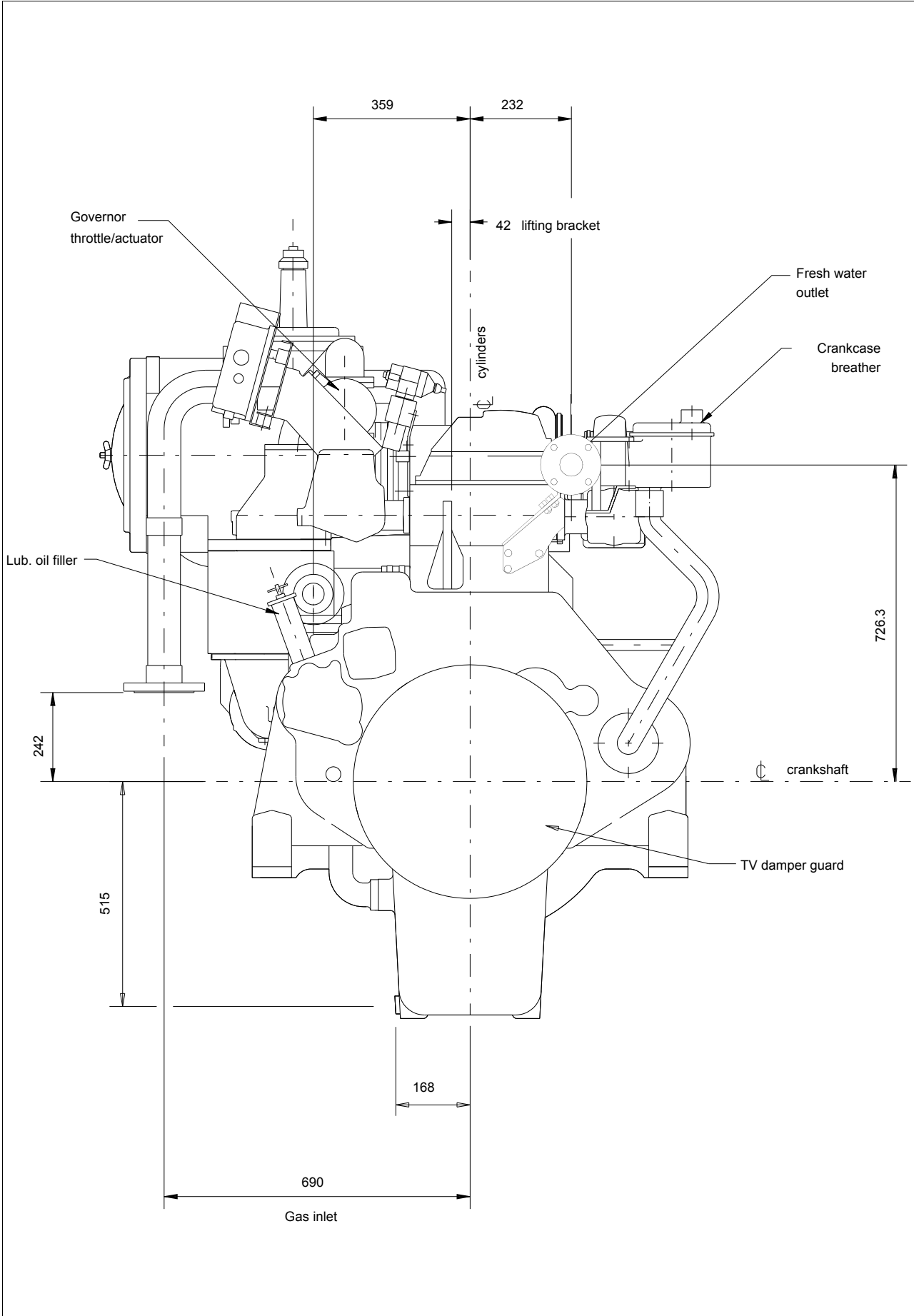

4008-30TRS1 and 4008-30TRS2 Bio gas cogeneration unit - Right view

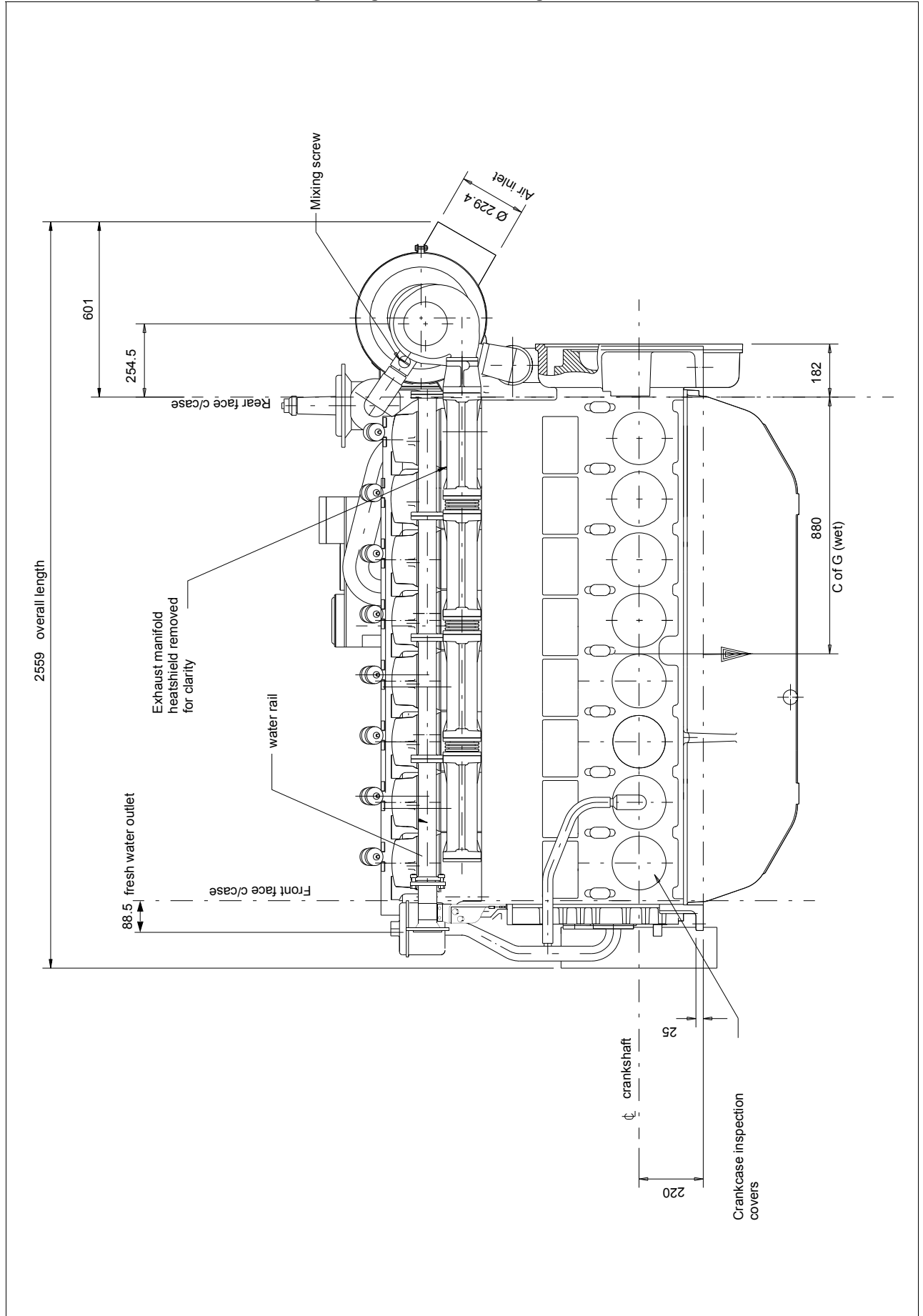

4008-30TRS1 and 4008-30TRS2 Bio gas cogeneration unit - Rear view

Exhaust outlet. system pipework must be adequately supported to ensure no load is exerted on turbocharger. (see detail)

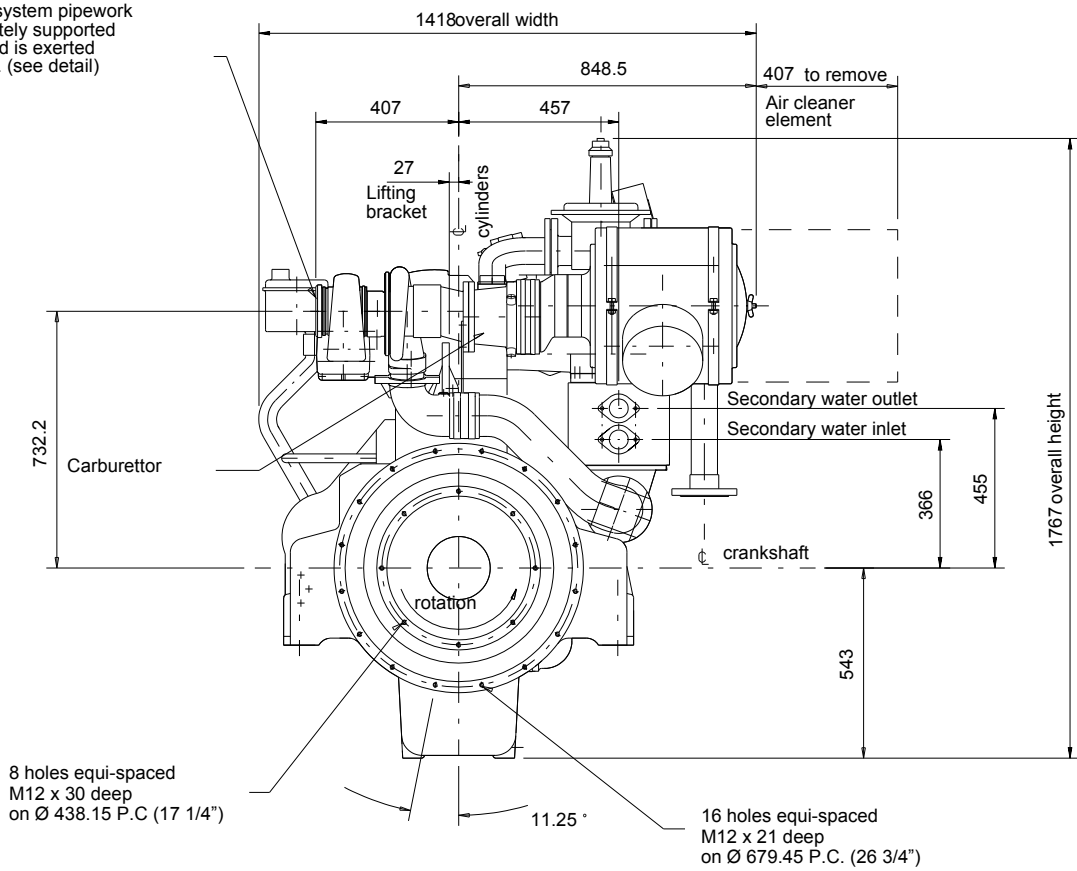

4008-30TRS1 and 4008-30TRS2 Bio gas cogeneration unit - SAE Flywheel, Exhaust Outlet and Support Pads

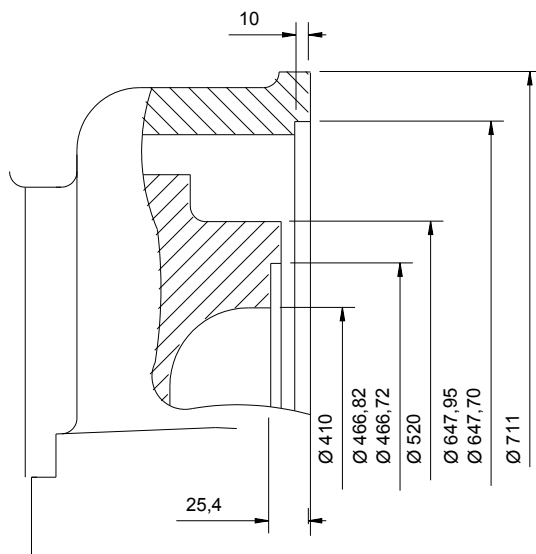

Detail of Sae 514 flywheel and SAE O flywheel housing (metric tappings) scale 1:5

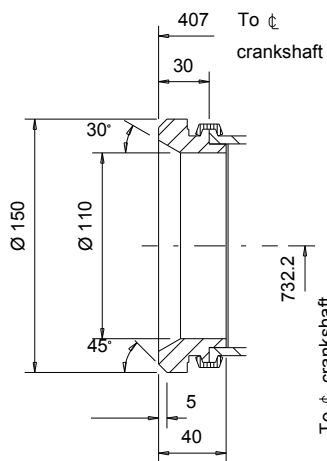

Detail of exhaust outlet Scale 1:2

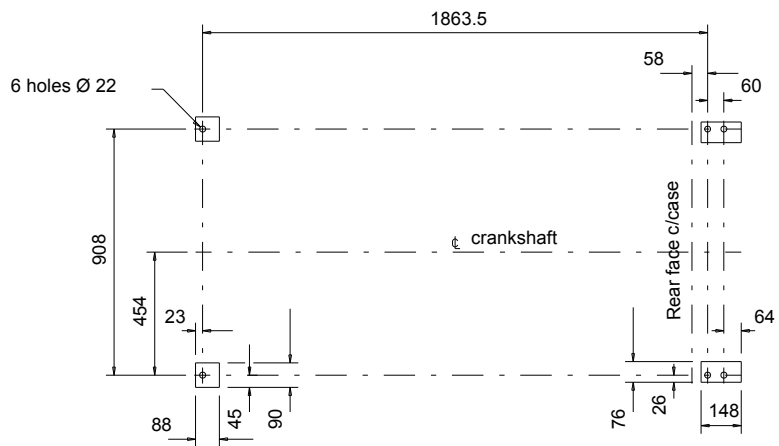

Plan view of support pads

4008-30TRS1 and 4008-30TRS2 Natural gas electro unit - Left view

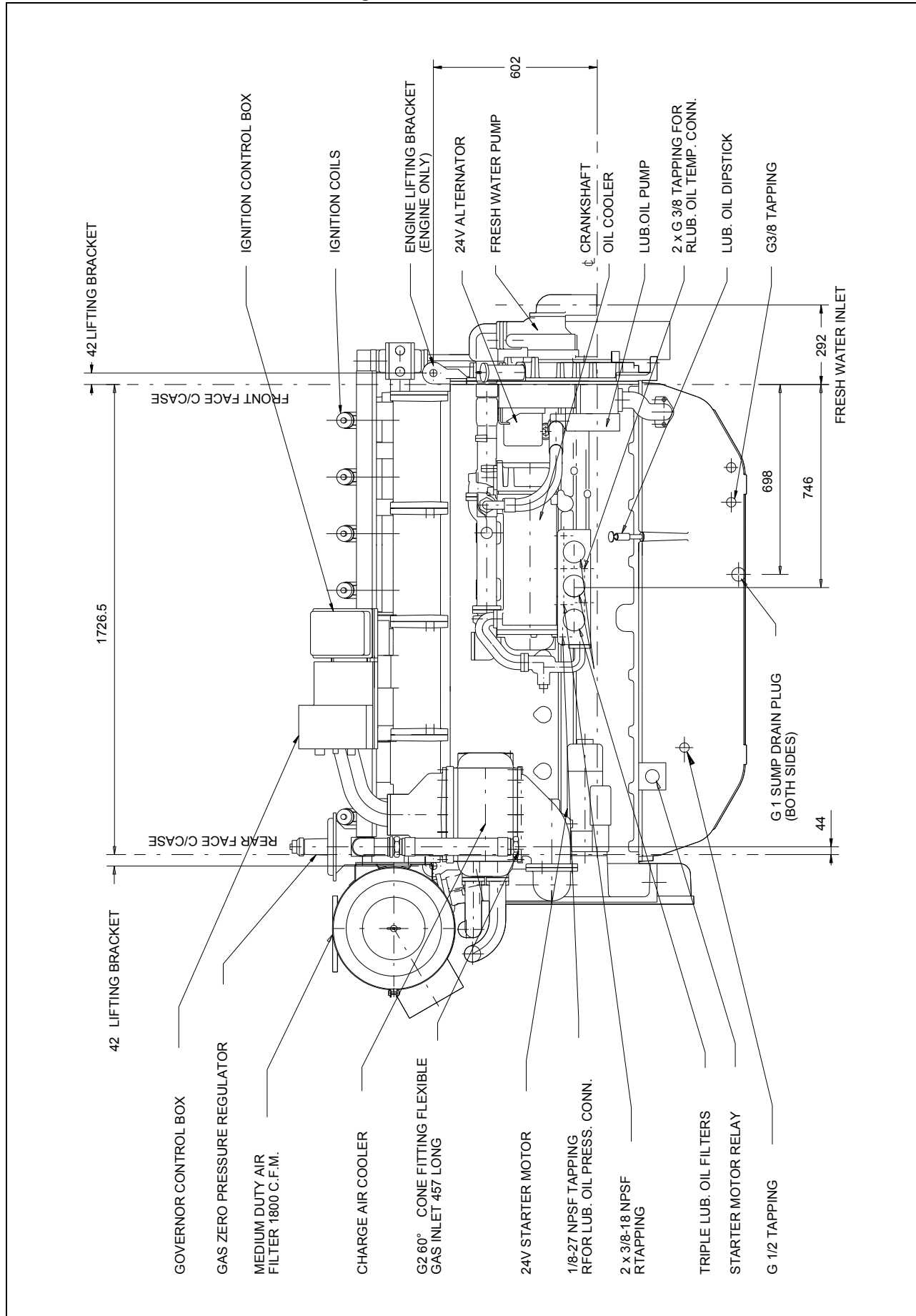

4008-30TRS1 and 4008-30TRS2 Natural gas electro unit - Front view

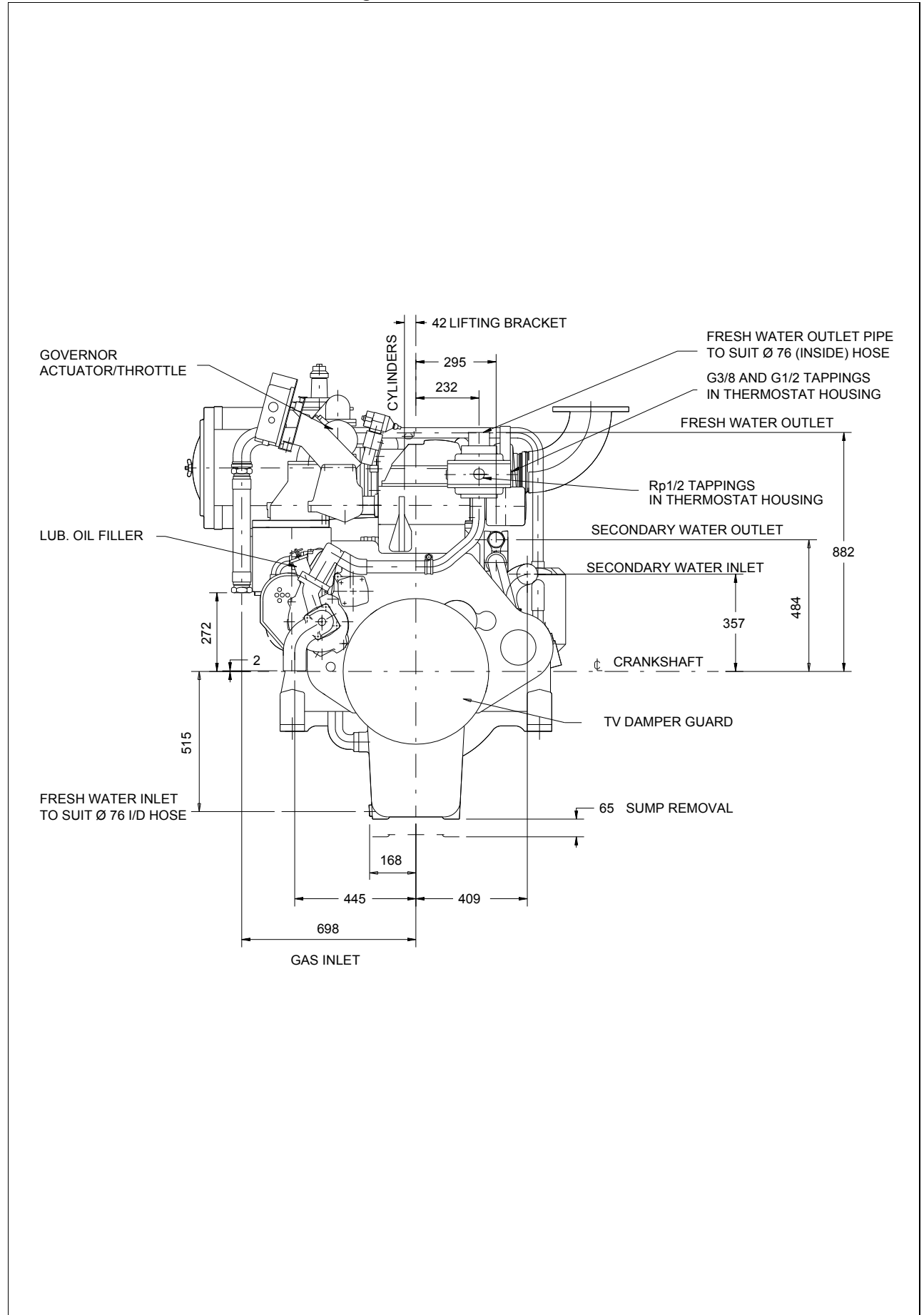

4008-30TRS1 and 4008-30TRS2 Natural gas electro unit - Right view

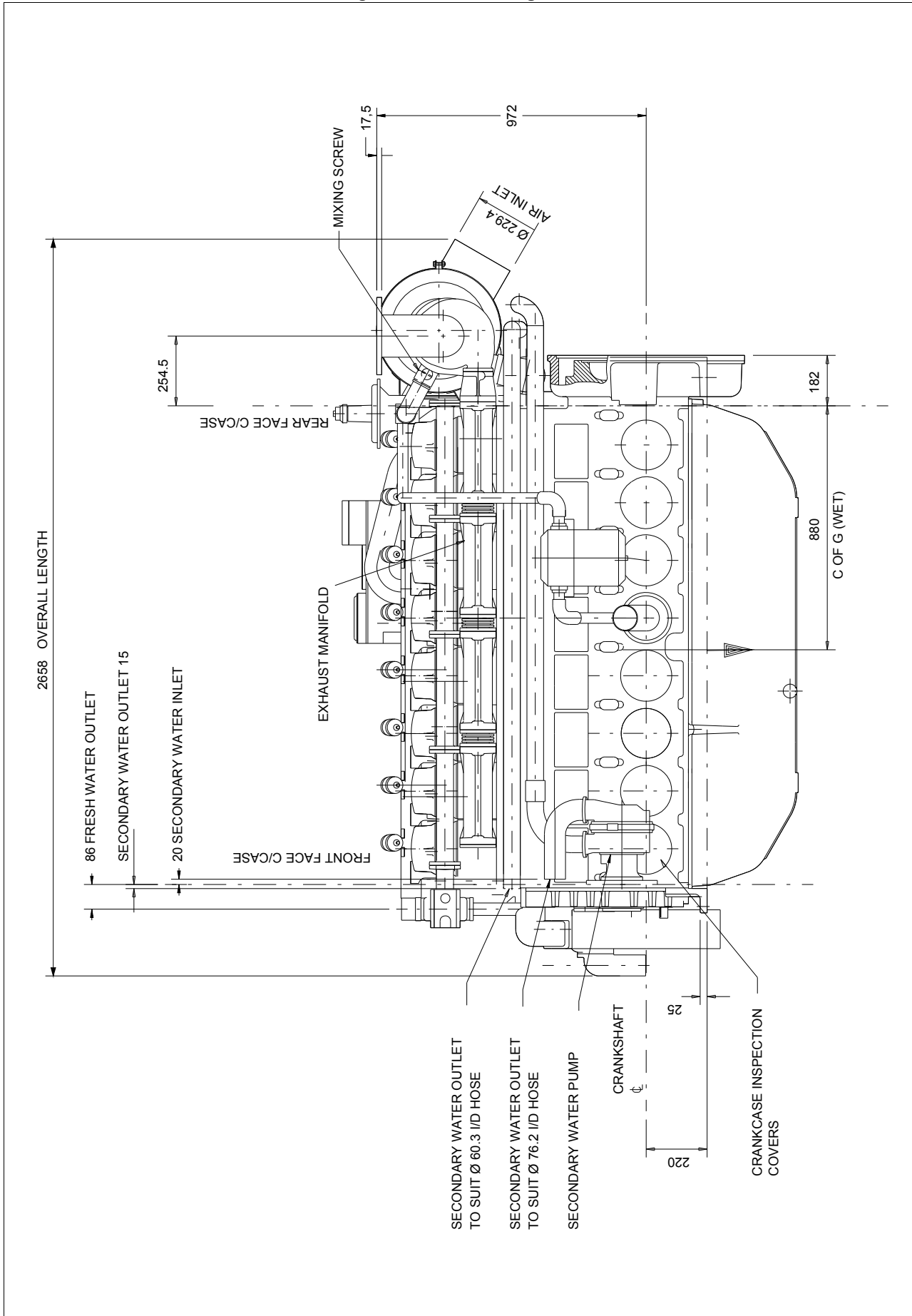

4008-30TRS1 and 4008-30TRS2 Natural gas electro unit - Rear view

EXHAUST OUTLET SYSTEM PIPEWORK
MUST BE ADEQUATELY SUPPORTED
TO ENSURE NO LOAD IS EXERTED
ON TURBOCHARGER. (SEE DETAIL)

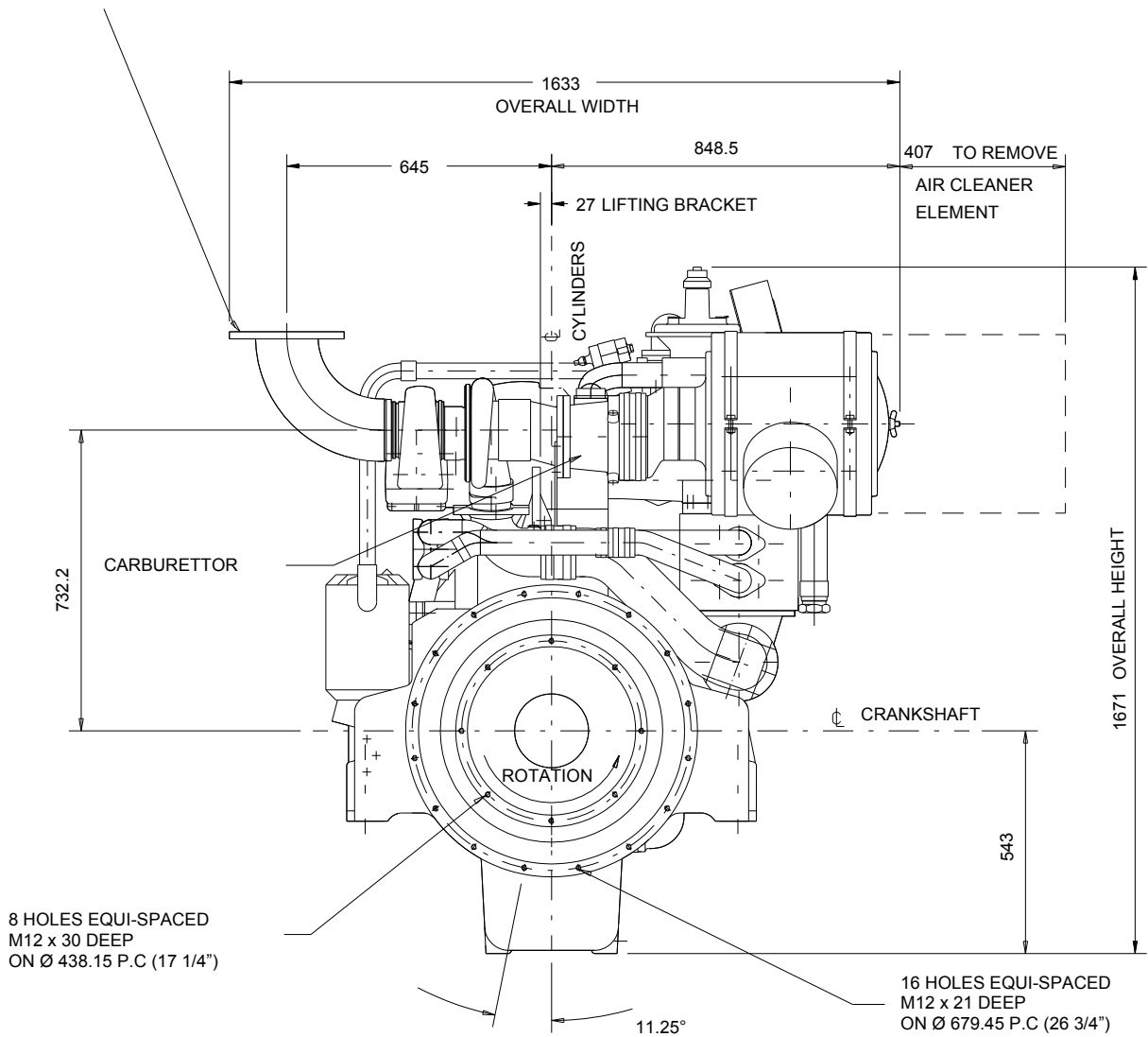

4008-30TRS1 and 4008-30TRS2 Natural gas electro unit - SAE Flywheel, Exhaust Outlet and Support Pads

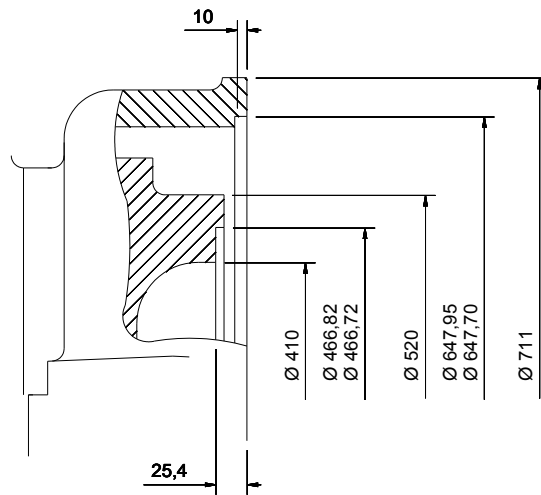

DETAIL OF SAE 514 FLYWHEEL
AND SAE O FLYWHEEL HOUSING
(METRIC TAPPINGS)
SCALE 1:5

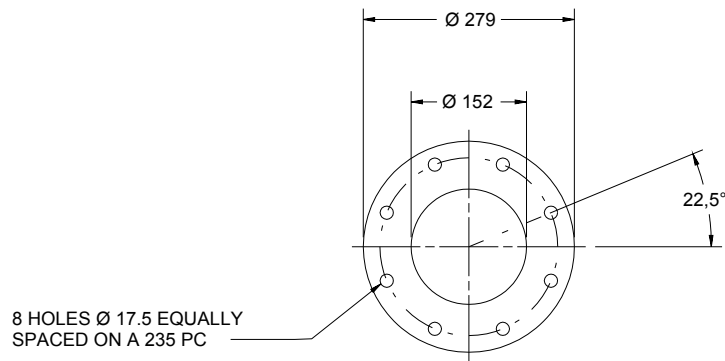

8 HOLES Ø 17.5 EQUALLY
SPACED ON A 235 PC

DETAIL OF EXHAUST OUTLET
SCALE 1:5

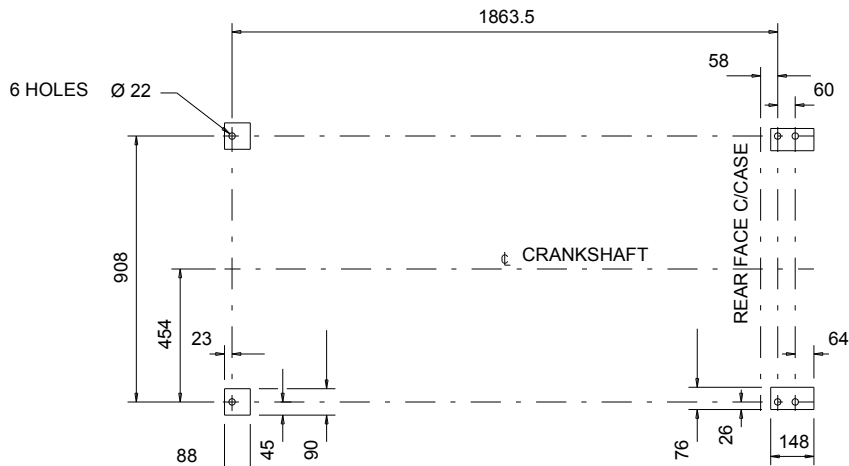

PLAN VIEW OF SUPPORT PADS

Derate tables

Raw water derate

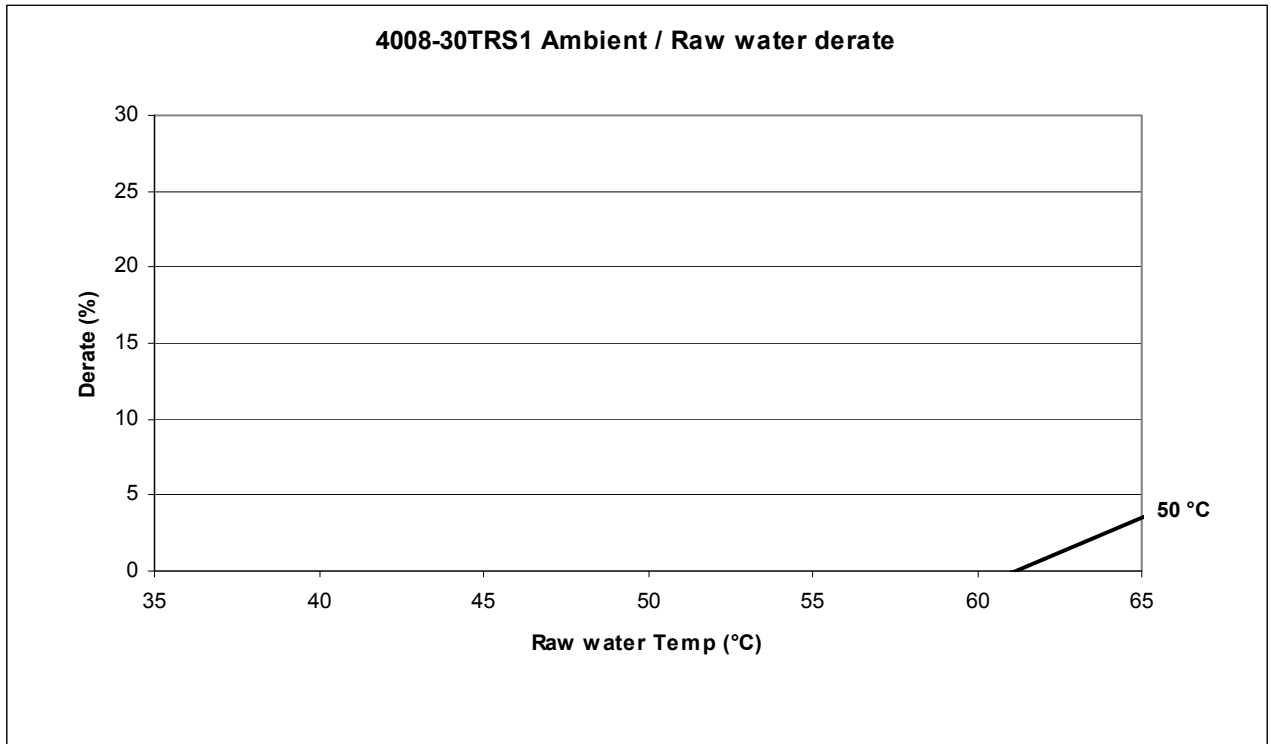

Ambient temperature derate

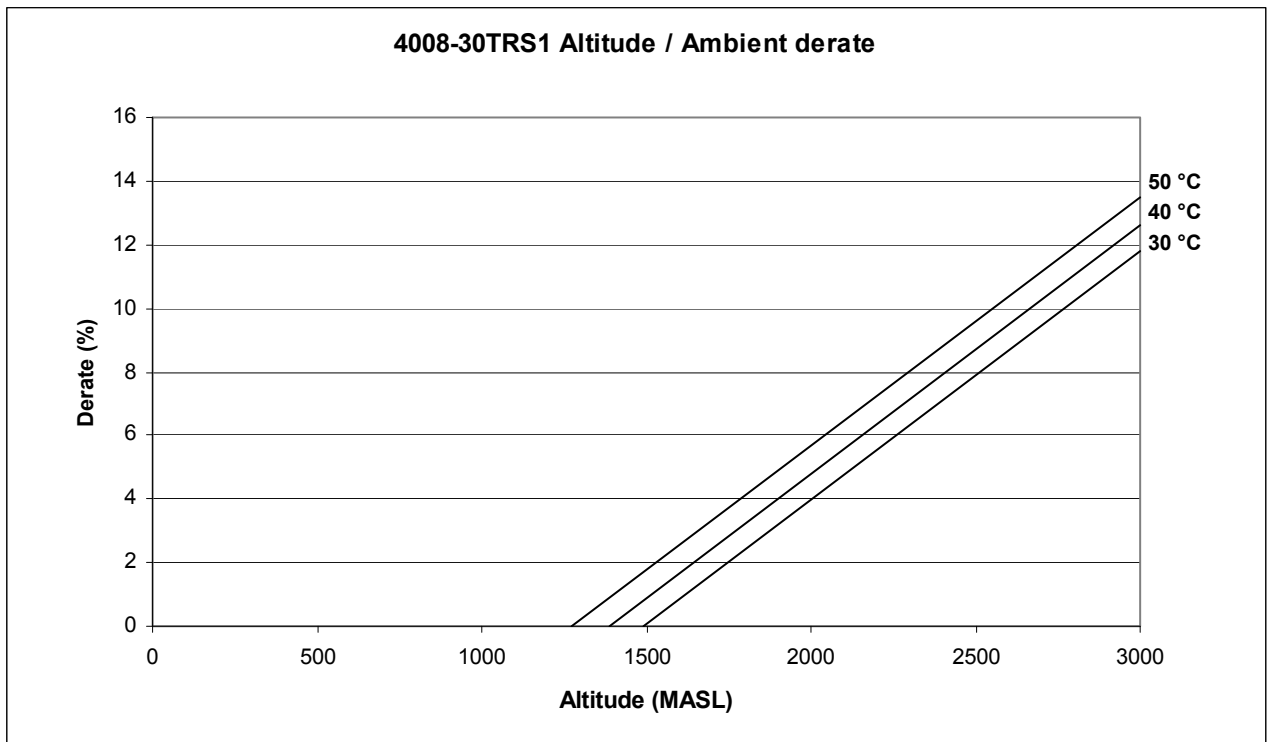

Raw water derate

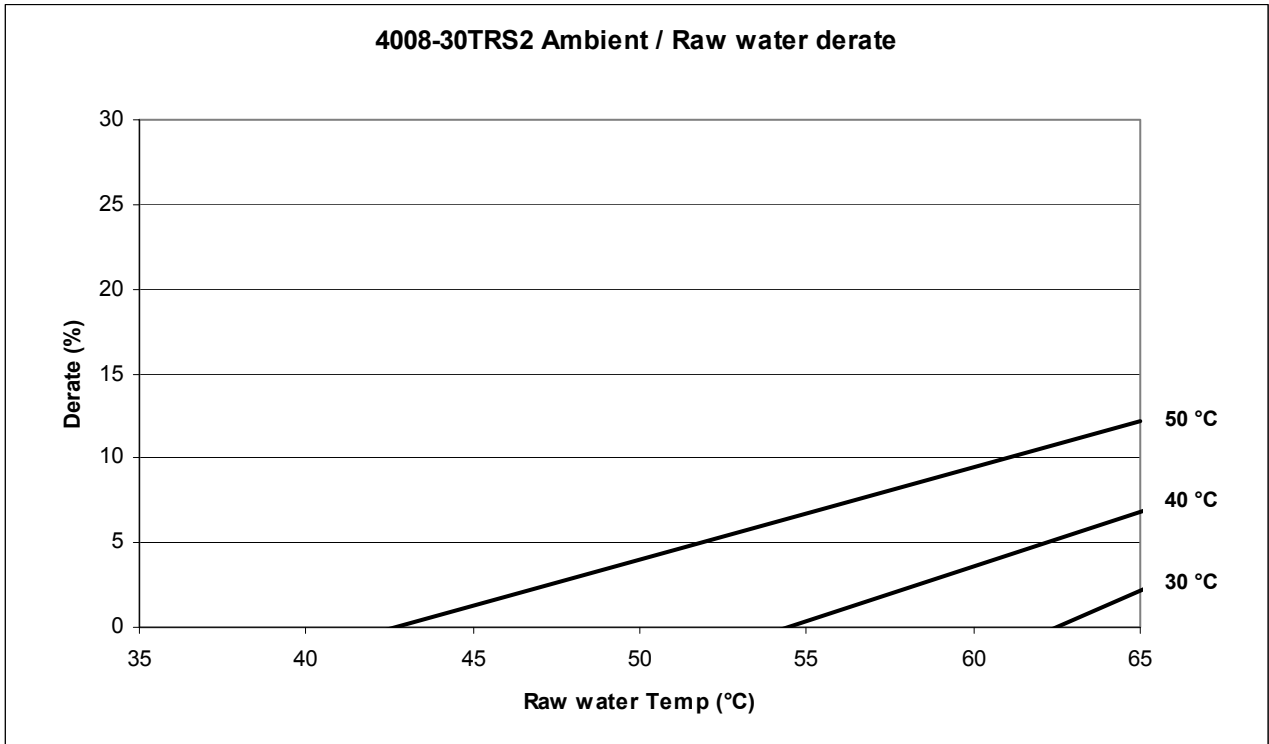

Ambient temperature derate

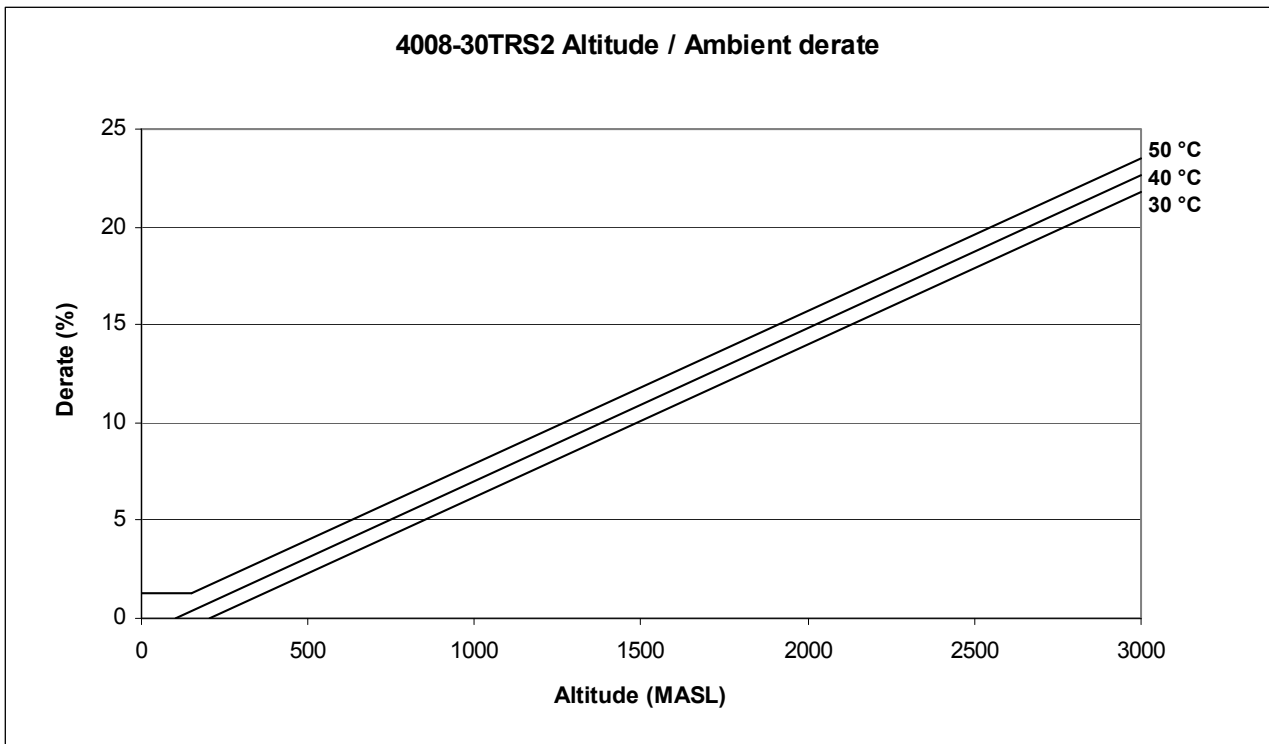

Induction system

Maximum air intake restriction of engine:

-clean filter	127 mm H ₂ O
-dirty filter	380 mm H ₂ O
-air filter type	1 of dry type

Exhaust emissions data

Ambient temperature of 25 °C

Emissions at continuous baseload rating.

If the engine is to operate in ambient conditions other than test conditions then suitable adjustments may be necessary for any change in inlet air temperature or barometric pressure.

Designation		TRS1	TRS2
Oxygen (O ²)	%	9,01	9,24
Oxides of Nitrogen (NOx)	mg/Nm ³	480	490
Hydrocarbons (THC)	mg/Nm ³	1160	1100
Carbon Monoxide (CO)	mg/Nm ³	791	774

Designation		Cogeneration unit		Electro unit	
Mass flow data		TRS1	TRS2	TRS1	TRS2
Combustion air (25 °C)	kg/h	2385	2766	2416	2802
Volume flow data					
Combustion air (25 °C)	m ³ /h	2040	2366	2067	2397

Exhaust system

Designation	Units	TRS1	TRS2
Maximum back pressure for total system	mm H ₂ O	600	400

Exhaust outlet flange size 1 x 152 mm

For recommended pipe sizes see the Installation Manual.

Designation		Cogeneration unit		Electro unit	
Volume flow data	Units	TRS1	TRS2	TRS1	TRS2
100 kPa					
Exhaust gas at turbo exit temperature	m ³ /h	5409	6215	5481	6296

Exhaust data		Units	TRS1	TRS2
Exhaust temperature		°C	487	478
Oxygen content in exhaust gas		%	9,01	9,24
Lambda		λ	1,71	1,70

Starting requirements temperature down to 0°C

Oil: refer to Perkins Engines Company Limited

Starter: 1 x 24 Volts

Battery: 2 x 12V total Ah 232

Inrush current to starter: 1000 amps

Cranking current: 600 amps

Starter cable size: 70 mm²

Maximum length: 6 m

Notes:

- Engines that are **not** equipped with additional A:F ratio control will require immersion heaters to be fitted when ambient temperatures are below 15 °C
- Engines fitted with additional A:F ratio control with start unaided down to 0 °C
- The battery capacity is defined by the 20 hour rate
- The starting ability of an engine with immersion heater will be improved by about 10 °C and the start aid specification can be modified accordingly. The oil specification should be for the minimum ambient temperature as the oil will not be warmed by the immersion heater
- Breakaway current is dependant on battery capacity available. Cables should be capable of handling the transient current which may be up to double the steady cranking current.

Electrical system

Type insulated return

Starter motor 24 volts

Starter motor power 7,5 kW

Number of teeth on flywheel 190

Number of teeth on starter motor 12

Minimum cranking speed 120 rev/min.

Pull in current of starter motor solenoid 26,8 amps at 24 volts

Hold in current of starter motor solenoid 9 amps at 24 volts

Ignition system

Primary system Altronic Disn 800

Primary voltage 24 volts

Polarity negative earth

Spark plug gap 0,25 mm

Ignition timing 24° BTDC

Noise levels

The figures for total noise levels are typical for an engine running at the continuous baseload power rating in a semi-reverberant environment and measured at a distance of one metre from the periphery of the engine (sound pressure level re: -20 x 10⁻⁶ pa).

Ambient noise level 70 dBA

4008-30TRS1 432 kWb

4008-30TRS2 526 kWb

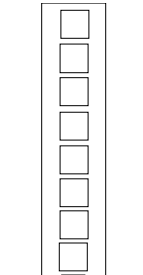
	Position 1 102,8 dBA		Position 1 102,3 dBA	
Position 7 102,7 dBA		Position 2 103,8 dBA	Position 7 103,5 dBA	Position 2 104,8 dBA
Position 6 103,3 dBA		Position 3 105,7 dBA	Position 6 103,5 dBA	Position 3 105,4 dBA
Position 5 104,5 dBA		Position 4 104,5 dBA	Position 5 104,2 dBA	Position 4 104,2 dBA

at position 7

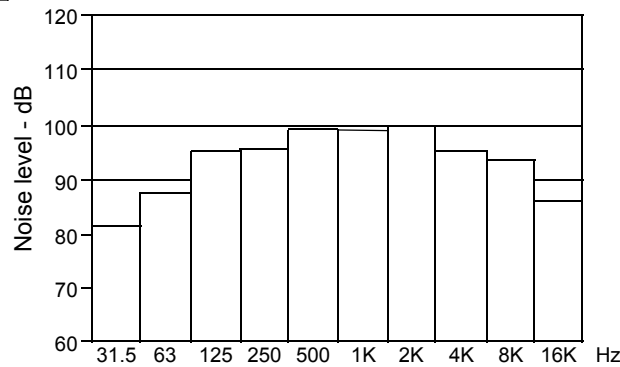

Engine mounting

Maximum additional load applied to flywheel due to all rotating components 650 kg

The information given on this Technical Data Sheet is for guidance only. For ratings other than those shown, please contact Perkins Engines Company Limited.



Perkins Engines Company Limited
Peterborough PE1 5NA United Kingdom
Telephone +44 (0) 1733 583000
Fax +44 (0) 1733 582240
www.perkins.com

Distributed by

All information in the document is substantially correct at the time of printing but may be subsequently altered by the company.